

Stronghold Tie Down Bracket Anchorage Guide

Anchor Specification for Each Bracket:

Stronghold Bracket Size	Stronghold Product Code	Anchor Size
Small	STD200-P	M20
Medium	STD320-P	M24
Large	STD440-P	M27

Total Anchor Qty. Required for Each Kit:

Kit Code	Anchor Size	Total Anchor Qty. Required
STD200-100	M20	2
STD200-150	M20	2
STD320-100	M24	2
STD320-150	M24	2
STD440-100	M27	1

Note:

Anchor quantity is for reference only and is not included in the kit.

For Short Wall Bracing System

To achieve the bracing capacity specified in Table 3-7 in the Short Wall Bracing Brochure, the anchor is designed by an anchor designer to ensure that the minimum anchor tie-down capacity is maintained as follows:

- M20 : 36 kN
- M24 : 54 kN

General Note:

The anchor is designed by an anchor designer to ensure that the anchor tie-down capacity of each Stronghold Tie Down Bracket meets or exceeds the values mentioned in Table 1-3 in the Stronghold Tie Down Brochure.

If this requirement cannot be fulfilled, the design tie down capacity should be reduced to the actual tie down capacity of the selected anchor.

It's important to emphasise that design tie-down capacities cannot surpass the figures specified in Table 1-3 in the Stronghold Tie Down Brochure.

Anchor Height:

- **Above Concrete Surface**
Anchor height above the concrete surface = bottom plate (can be 35mm or 45mm) + (Min. 20mm + anchor nut height; Max. 50mm to prevent protrusion into the GLT).
- **Embedment Depth:**
Anchor embedment depth to be specified by the anchor designer.

Edge Distances:

Minimum edge distances to be specified by the anchor designer.

Anchor Hole Diameter:

The anchor hole diameter should align with the recommendation provided by the anchor supply company.

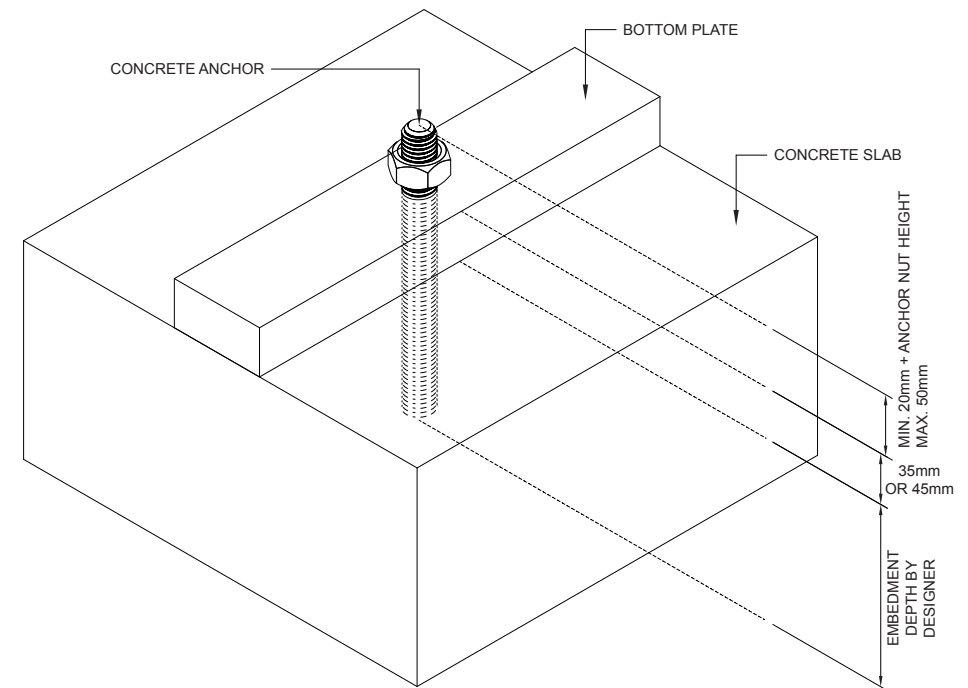

Shortwall Bracing Anchor Spacing:

The spacing between two Short Wall bracing anchors depends on the selected bracing application. To determine the distance between anchor points, refer to the following details.

Brackets Inside (Option 1)

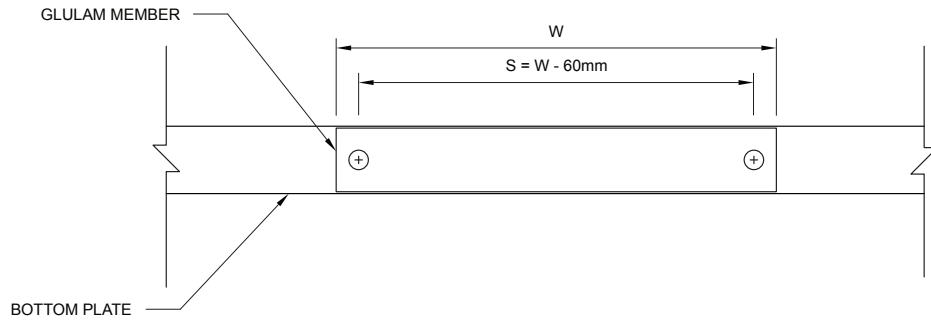

Brackets Outside with A Double Stud Wall (Option 3)

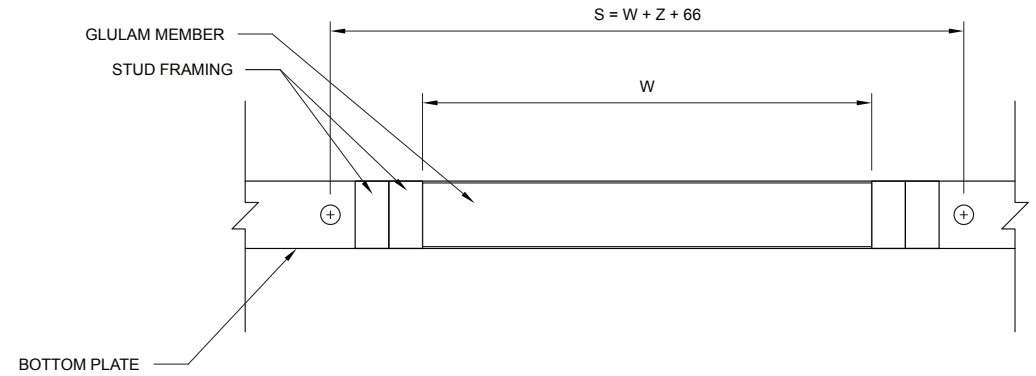

Brackets Outside with A Single Stud Wall (Option 2)

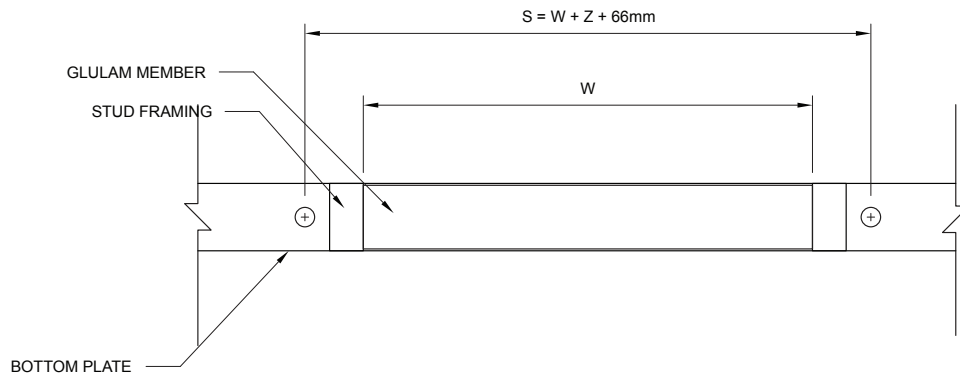

Brackets Outside with A Single And Double Stud Wall (Option 4)

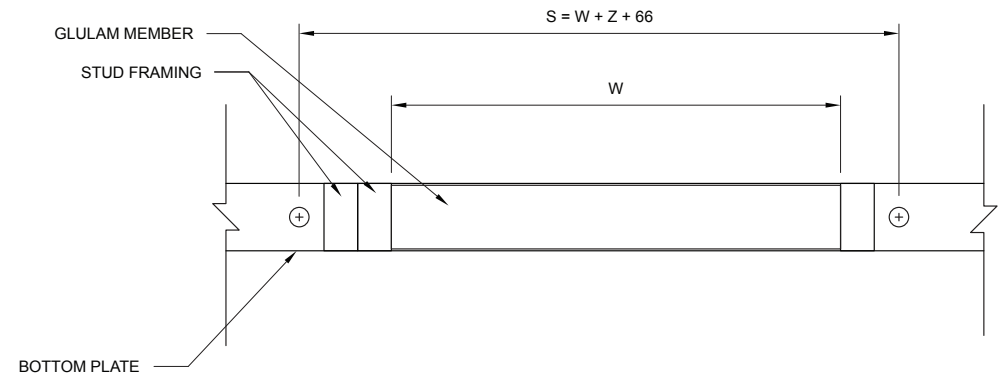

W = SIZE OF GLT MEMBER INCLUDING TOLERANCE (200-600mm)

Z = TOTAL THICKNESS (mm) OF ALL STUDS IN BETWEEN TWO STRONGHOLD TIE-DOWN BRACKETS

S = SPACING BETWEEN ANCHORS