

# Multinail Advance Short Wall Bracing

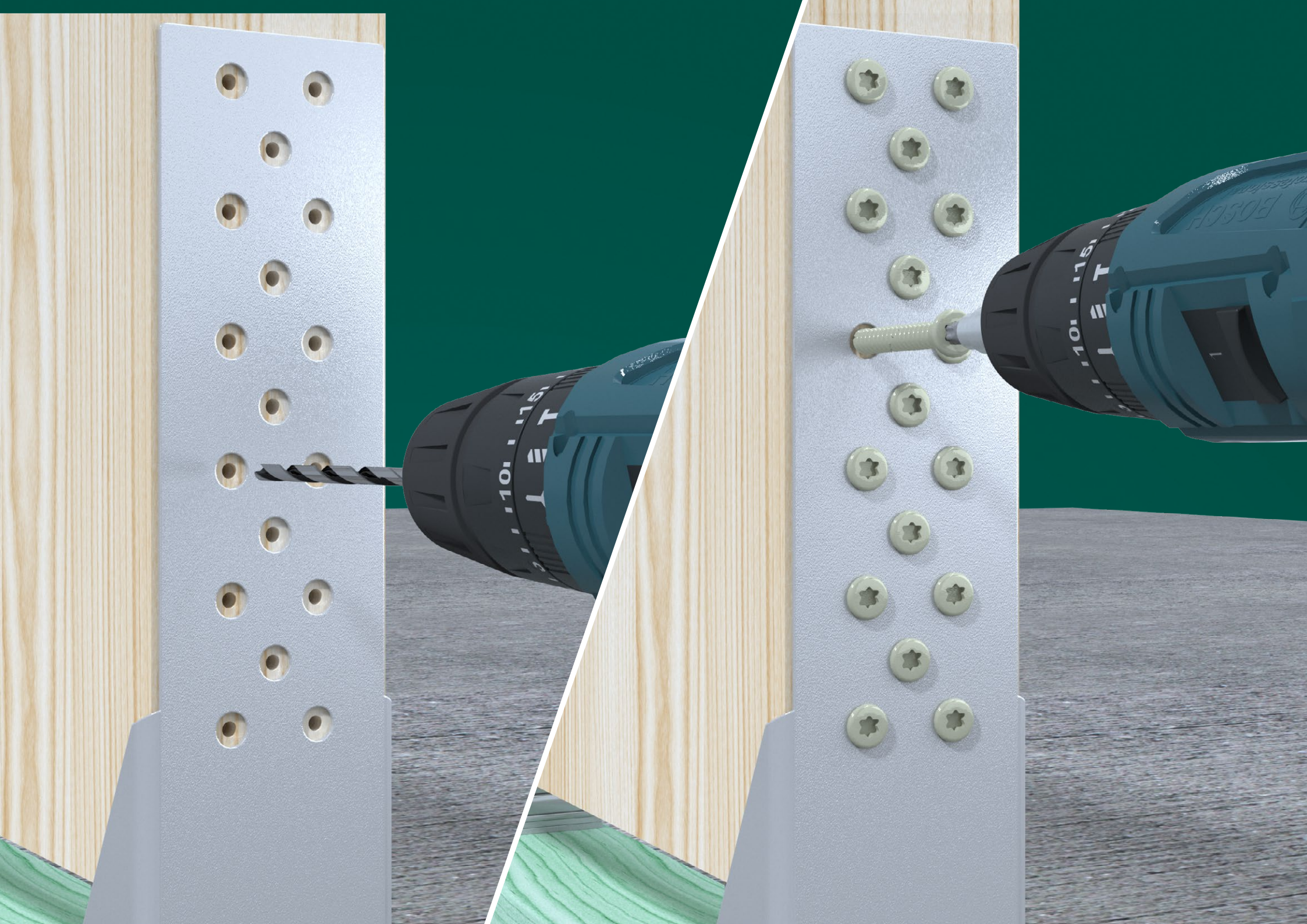



## About Multinail

Multinail is an Australian family-owned business established for over 40 years with all its products engineered, tested and manufactured at our industry-leading facility in Queensland, Australia.

The company specialises in the provision of quality metal connectors, software and engineering services to our partner network of licensed timber fabricators. Together, we offer an industry-wide service supplying prefabricated structural systems designed and engineered for optimising the efficiency and quality of timber construction.

## About Multinail Advance

Multinail Advance is an exciting addition to the Multinail Brand. Our core focus is to introduce Multinail's extensive range of products and services to new markets while innovating and developing solutions tailored to both existing and emerging sectors.

Our primary focus includes multi-residential projects, mid-rise buildings, and mass timber construction.

Multinail Advance is committed to enhancing the competitive edge of our fabricators by expanding timber construction into new markets and contributing to the growth of the Australian timber industry.





## The Advantages of Short Wall Bracing

- Tailored to fulfill the bracing requirements of open-plan housing, accommodating fewer internal walls and larger openings.
- Offers superior bracing capacity compared to conventional sheet bracing units.
- Requires fewer screws, reducing on-site labor.
- Available in standardised kits for easy installation.

## Testing

Each Multinail Advance product undergoes rigorous testing to ensure its suitability and compliance with Australian engineering codes and standards.

Specifically, the hold-down capacity of the Stronghold tie-down brackets has undergone extensive in-house testing using glulam samples sourced from Australian suppliers that feature locally grown timber species. The primary objective of this testing was to validate both the capacities of the steel brackets and their connection to timber using screws.

The results from these tests exceeded the theoretical benchmarks established in accordance with AS1720.1.

It's important to note, though, that the concrete anchor tie-down capacity wasn't tested due to varying governing factors such as concrete grade, slab depth, and specifications from different anchor suppliers. Therefore, it becomes the responsibility of the designer to specify suitable concrete anchors for the short wall bracing system.



## Design parameters

Short wall bracing using a Stronghold tie-down bracket can provide various options depending on the bracing requirements, ranging from non-cyclonic to cyclonic regions.

The ultimate design capacity tables provided in this brochure are based on the parameters (more information, refer to AS1720.1) below:

- STD200 to be used in a 70mm wall frame; STD320 to be used in a 90mm wall frame
- Timber joint group JD4 and better
- Application of structural member Category 1 (AS1720.1 Table 2.2)
- When used in Category 2, apply a reduction factor of 0.94 for STD200 kits; no reduction factor is required for STD320 kits
- Concrete anchor (M20) shall have a minimum tie-down capacity of 36kN for STD200
- Concrete anchor (M24) shall have a minimum tie-down capacity of 54kN for STD320
- Precalculated values are for bracing only, non-load bearing walls.
- The design properties of GL grades specified in this brochure is based on standard characteristic values in Table 7.1 AS1720.1. While for GL15, it has a minimum design properties of:
  - Bending ( $f_b$ ) = 36 MPa
  - Shear ( $f_s$ ) = 4.2 MPa
  - Compression parallel to grain ( $f_c$ ) = 33 MPa
  - Modulus of Elasticity ( $E$ ) = 14800 MPa
- Horizontal deflection control value is 12mm on top of the Glulam member

If design requirements fall outside of the parameters above, please get in touch with Multinail Advance for advice.

# Kit Suitability

**Table 1:**  
Kit Suitability with GLT sizes

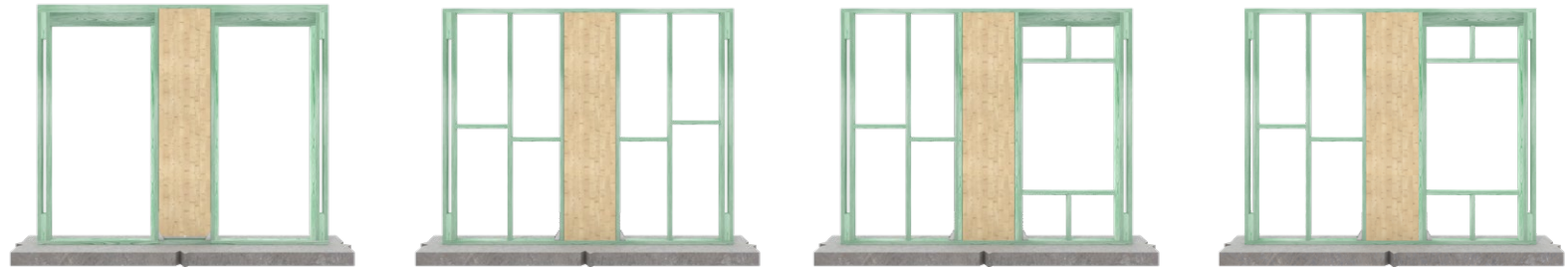

GLT size	Brackets inside	Brackets outside with a single stud wall	Brackets outside with a double stud wall	Brackets outside with a single and double stud wall
230x65 - 495x65	STD200-100		STD200-150	
195x85 - 525x85	STD320-100		STD320-150	

**Table 2:**  
Kit Suitability with timber web bracing truss

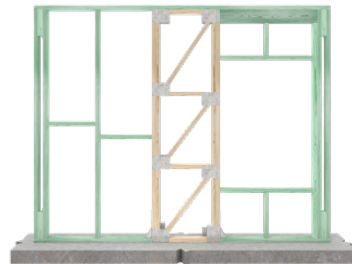

Truss size	Timber web bracing truss
450-900mm	STD320-150

## Brackets inside

Ultimate lateral bracing capacities based on some standard GLT sizes and nominal wall height has been pre-calculated and provided in Table 3.

Minimal GL grades have been colour coded. Linear extrapolation or interpolation are NOT permitted. Please check with the designer regarding the ultimate bracing capacity if the GLT sizes or grades are outside of the provided capacity table.



**Table 3:** Option 1 Ultimate Bracing Capacity (kN)

GLT member size	Wall height (mm)				Kit
	2440	2590	2740	3000	
230x65	3.2	3.0	2.8	2.4	STD200-100
260x65	3.6	3.4	3.2	2.9	
295x65	4.1	3.9	3.6	3.3	
330x65	4.6	4.3	4.1	3.7	
360x65	5.0	4.7	4.5	4.1	
395x65	5.5	5.2	4.9	4.5	
425x65	5.9	5.6	5.3	4.8	
460x65	6.4	6.1	5.7	5.2	
495x65	6.9	6.5	6.0	5.6	STD320-100
195x85	3.5	2.9	2.5	1.9	
230x85	5.0	4.7	4.1	3.1	
260x85	5.7	5.4	5.1	4.5	
295x85	6.5	6.1	5.8	5.3	
330x85	7.3	6.8	6.5	5.9	
360x85	7.9	7.5	7.0	6.4	
395x85	8.7	8.2	7.7	7.1	
425x85	9.4	8.8	8.3	7.6	
460x85	10.1	9.5	9.0	8.2	
495x85	10.9	10.3	9.7	8.9	
525x85	11.6	10.9	10.3	9.4	

Legend for minimum grade

GL18	GL17	GL15	GL13
------	------	------	------





## Brackets outside with a single stud wall

Ultimate lateral bracing capacities based on some standard GLT sizes and nominal wall height has been pre-calculated and provided in Table 4.

Minimal GL grades have been colour coded. Linear extrapolation or interpolation are NOT permitted. Please check with the designer regarding the ultimate bracing capacity if the GLT sizes or grades are outside of the provided capacity table.

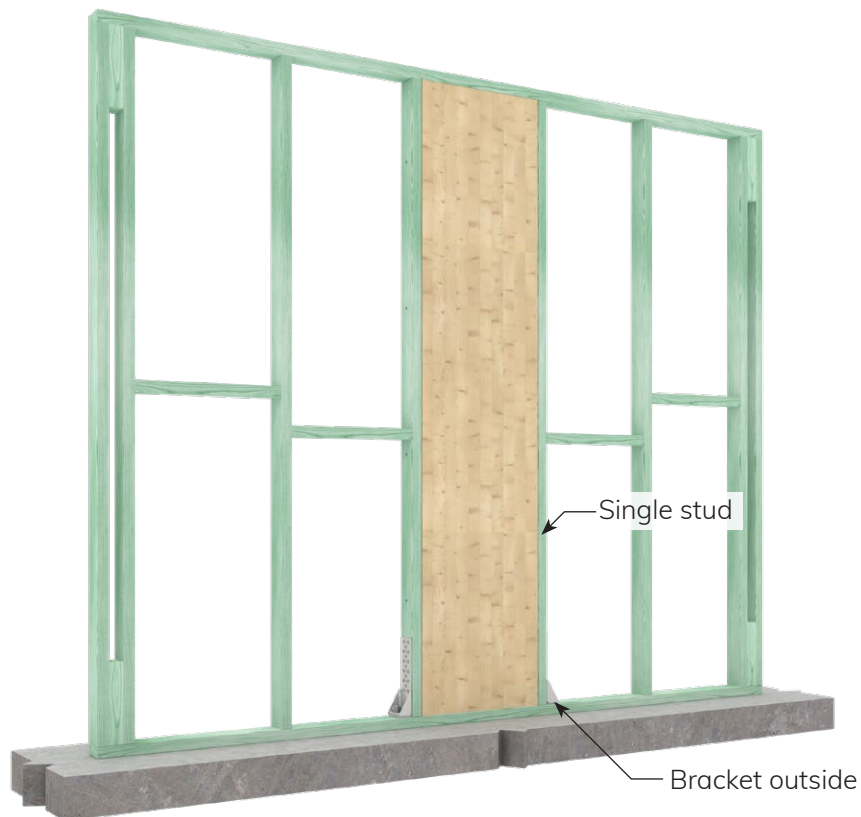

**Table 4:** Option 2 Ultimate Bracing Capacity (kN)

GLT member size	Wall height (mm)				Kit
	2440	2590	2740	3000	
230x65	4.2	3.7	3.1	2.4	STD200-100
260x65	4.6	4.3	4.1	3.4	
295x65	5.1	4.8	4.5	4.1	
330x65	5.6	5.3	5.0	4.5	
360x65	6.0	5.7	5.3	4.9	
395x65	6.5	6.1	5.8	5.3	
425x65	7.0	6.6	6.2	5.7	
460x65	7.4	7.0	6.6	6.0	
495x65	7.9	7.4	7.0	6.4	
195x85	3.5	2.9	2.5	1.9	
230x85	5.8	4.8	4.1	3.1	
260x85	7.3	6.8	5.9	4.5	
295x85	8.0	7.6	7.1	6.5	
330x85	8.8	8.3	7.8	7.2	
360x85	9.5	8.9	8.4	7.7	
395x85	10.2	9.6	9.1	8.3	
425x85	10.9	10.3	9.7	8.9	
460x85	11.7	11.0	10.4	9.5	
495x85	12.5	11.7	11.1	10.1	
525x85	13.1	12.4	11.7	10.7	

Legend for minimum grade

GL18	GL17	GL15	GL13
------	------	------	------



# Brackets outside with a double stud wall

Ultimate lateral bracing capacities based on some standard GLT sizes and nominal wall height has been pre-calculated and provided in Table 5.

Minimal GL grades have been colour coded. Linear extrapolation or interpolation are NOT permitted. Please check with the designer regarding the ultimate bracing capacity if the GLT sizes or grades are outside of the provided capacity table.

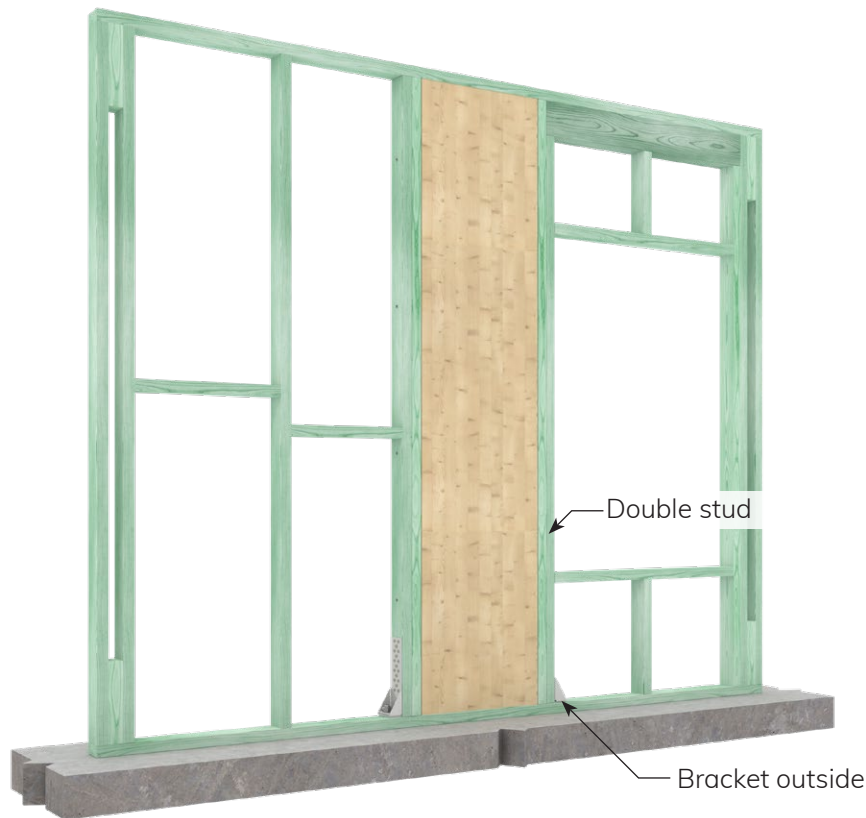

**Table 5:** Option 3 Ultimate Bracing Capacity (kN)

GLT member size	Wall height (mm)				Kit
	2440	2590	2740	3000	
230x65	4.4	3.7	3.1	2.4	STD200-100
260x65	5.6	5.3	4.5	3.4	
295x65	6.1	5.7	5.4	4.9	
330x65	6.6	6.2	5.8	5.3	
360x65	7.0	6.6	6.2	5.7	
395x65	7.5	7.0	6.7	6.1	
425x65	7.9	7.4	7.0	6.4	
460x65	8.4	7.9	7.5	6.8	
495x65	8.9	8.4	7.9	7.2	
195x85	3.5	2.9	2.5	1.9	
230x85	5.8	4.8	4.1	3.1	
260x85	8.4	7.0	5.9	4.5	
295x85	9.6	9.0	8.5	6.5	
330x85	10.4	9.7	9.2	8.4	
360x85	11.0	10.4	9.8	9.0	
395x85	11.8	11.1	10.5	9.6	
425x85	12.5	11.7	11.1	10.1	
460x85	13.2	12.5	11.8	10.8	
495x85	14.0	13.2	12.5	11.4	
525x85	14.7	13.8	13.1	11.9	

Legend for minimum grade

GL18	GL17	GL15	GL13
------	------	------	------



## Brackets outside with a single and double stud wall

Ultimate lateral bracing capacities based on some standard GLT sizes and nominal wall height has been pre-calculated and provided in Table 6.

Minimal GL grades have been colour coded. Linear extrapolation or interpolation are NOT permitted. Please check with the designer regarding the ultimate bracing capacity if the GLT sizes or grades are outside of the provided capacity table.

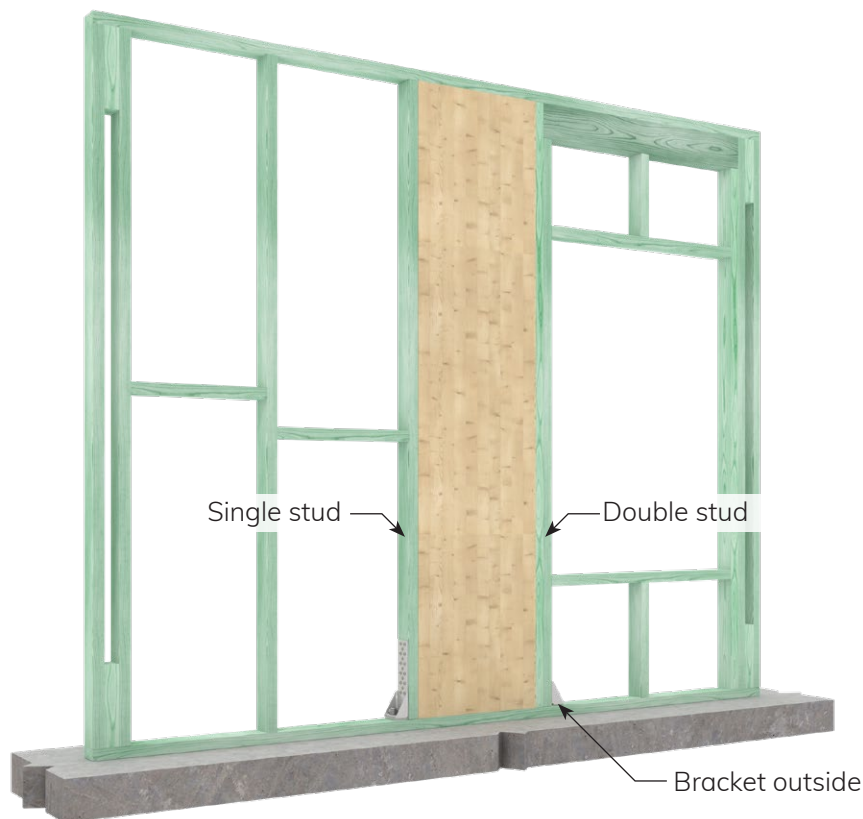

**Table 6:** Option 4 Ultimate Bracing Capacity (kN)

GLT member size	Wall height (mm)				Kit
	2440	2590	2740	3000	
230x65	4.4	3.7	3.1	2.4	STD200-100
260x65	5.1	4.8	4.5	3.4	
295x65	5.6	5.3	5.0	4.5	
330x65	6.1	5.7	5.4	4.9	
360x65	6.5	6.1	5.8	5.3	
395x65	7.0	6.6	6.2	5.7	
425x65	7.4	7.0	6.6	6.0	
460x65	7.9	7.4	7.0	6.4	
495x65	8.4	7.9	7.5	6.8	
195x85	3.5	2.9	2.5	1.9	
230x85	5.8	4.8	4.1	3.1	
260x85	8.0	7.0	5.9	4.5	
295x85	8.8	8.3	7.8	6.5	
330x85	9.6	9.0	8.5	7.8	
360x85	10.2	9.6	9.1	8.3	
395x85	11.0	10.4	9.8	9.0	
425x85	11.7	11.0	10.4	9.5	
460x85	12.5	11.7	11.1	10.1	
495x85	13.2	12.5	11.8	10.8	
525x85	13.9	13.1	12.4	11.3	

Legend for minimum grade

GL18	GL17	GL15	GL13
------	------	------	------



# Timber web bracing truss

Pre-engineered timber web short wall member using Multinail nailplates



**Table 7:** Ultimate Bracing Capacity (kN/m)

Stronghold Tie Down	Width (mm)	Nominal wall height (mm)
		Up to 2700
STD320-150	450-900	12.0

Minimum 450mm and maximum 900mm

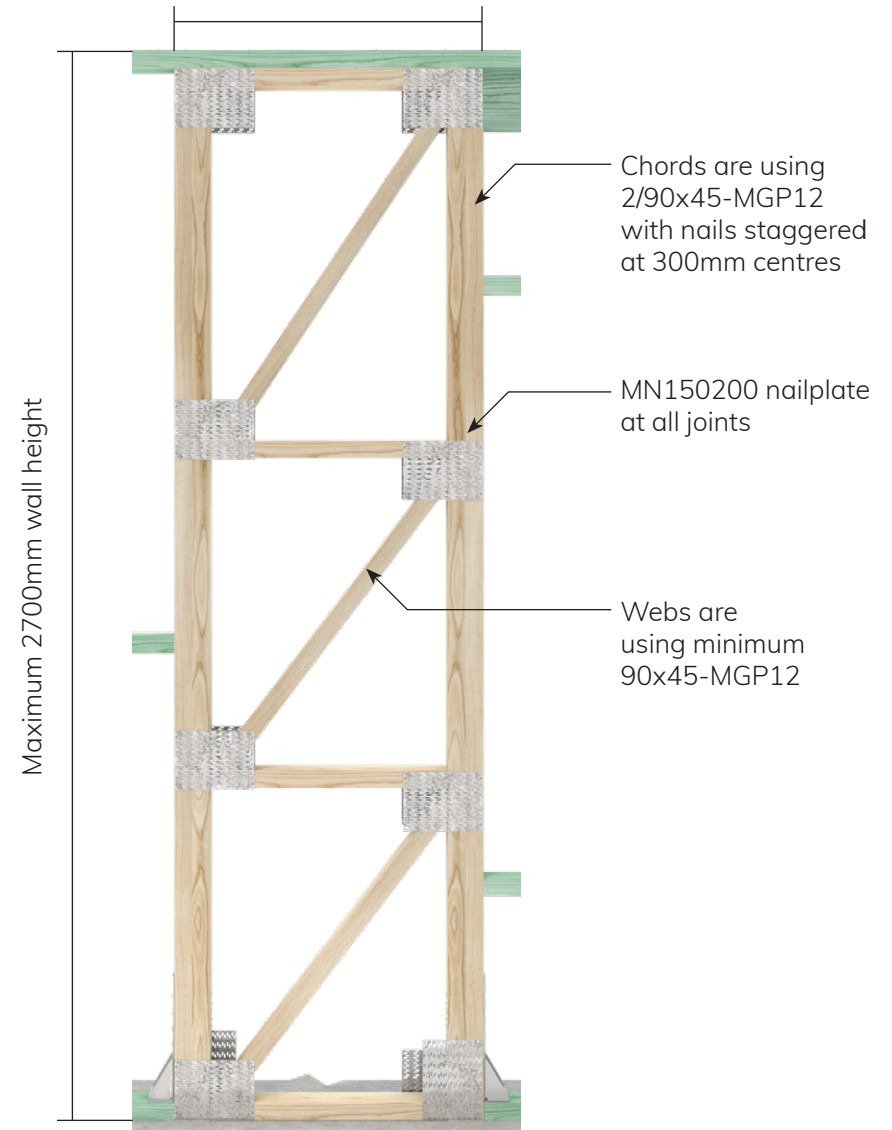

# Kit Contents

**Table 8:** Kit Content

Kit code	Stronghold Tie Down	Washer	Spacer	Screws	Instruction Manual
STD200-100	2	2	6	50	1
STD200-150	2	2	6	50	1
STD320-100	2	2	6	50	1
STD320-150	2	2	6	50	1

Note: concrete anchor is NOT included



**STD200-100** contains 100mm long screws  
**STD200-150** contains 150mm long screws



**STD320-100** contains 100mm long screws  
**STD320-150** contains 150mm long screws

# Technical Specifications

## Stronghold Tie Down

**Steel**  
G350 Steel, Powder Coated, 3mm Thickness

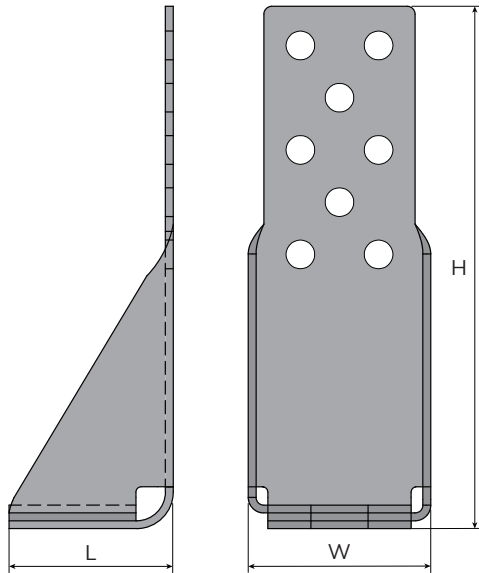

## Washer

**Steel**  
G350 Steel, Powder Coated, 10mm Thickness

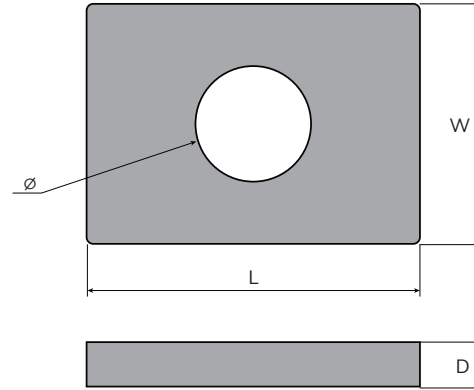

## Spacer

**Steel**  
G350 Steel, Powder Coated, 10mm Thickness

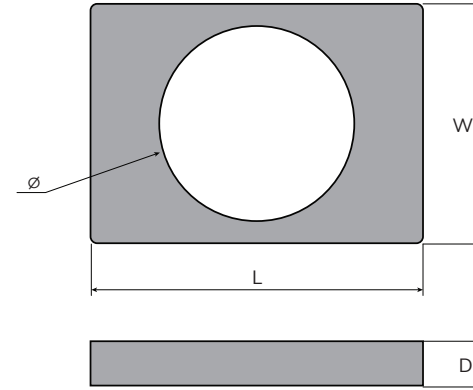

## Screws

**Steel**  
Hardened carbon steel, Electrocoated

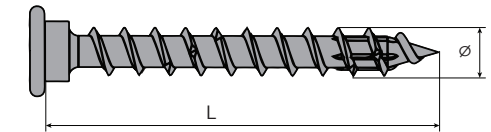

## Description and Packing

Product Code	Description H x W x L
STD200-P	200mm x 70mm x 63mm
STD320-P	320mm x 90mm x 63mm

Product Code	Description W x L x D x Ø
STD200W-P	54mm x 54mm x 10mm x Ø22mm
STD320W-P	54mm x 75mm x 10mm x Ø26mm

Product Code	Description W x L x D x Ø
STD200S-P	54mm x 54mm x 10mm x Ø37mm
STD320S-P	54mm x 75mm x 10mm x Ø44mm

Product Code	Description Ø x L	Carton Qty
CF08100-25	Ø8x100mm	25
CF08150-25	Ø8x150mm	25





**Multinail Australia Pty. Ltd.**  
155 Burnside Road, Stapylton  
QLD 4207, Australia  
Phone: +61 (0)7 3297 3250  
Email: [advance@multinail.com](mailto:advance@multinail.com)  
[www.multinail.com.au](http://www.multinail.com.au)